

# CM3312R111R-10

**UNCONTROLLED DOCUMENT**

**PHYSICAL DIMENSIONS:**

A	8.50	[.335]	± 0.25	[.010]
B	3.05	[.120]	± 0.25	[.010]
C	2.36	[.093]	± 0.25	[.010]
D	1.14	[.045]	± 0.13	[.005]
E	0.76	[.030]	± 0.18	[.007]

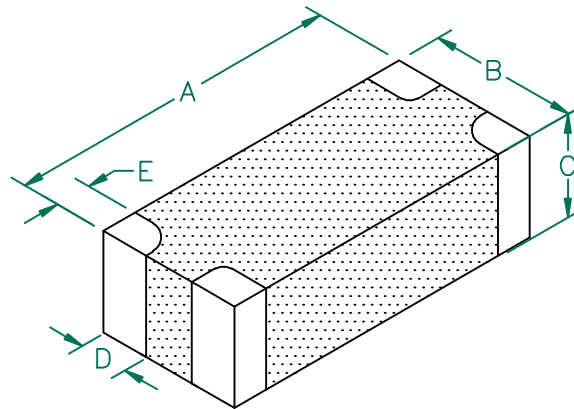

COMMON MODE ELECTRICAL CHARACTERISTICS:				
	COMMON MODE Z @ 100 MHz (Ω)	COMMON MODE Z @ 500 MHz (Ω)	DCR (Ω)	CONTINUOUS Rated Current
<b>Nominal</b>	110	<b>Nominal (Ref)</b> 150		
<b>Minimum</b>	83	-		
<b>Maximum</b>	138	-	0.005	5,000 mA

NOTES: UNLESS OTHERWISE SPECIFIED

1. TAPED AND REELED per CURRENT EIA SPECIFICATIONS 13" REELS, 2500 PCS/REEL.
2. COMPONENTS SHOULD BE ADEQUATELY PREHEATED BEFORE SOLDERING.
3. U.S. PATENT 6,288,626 SHOULD APPEAR ON THE LABEL OF EACH REEL OF PACKAGED PARTS.
4. TERMINATION FINISH IS 100% TIN.

Z vs. FREQUENCY (C,N,O)

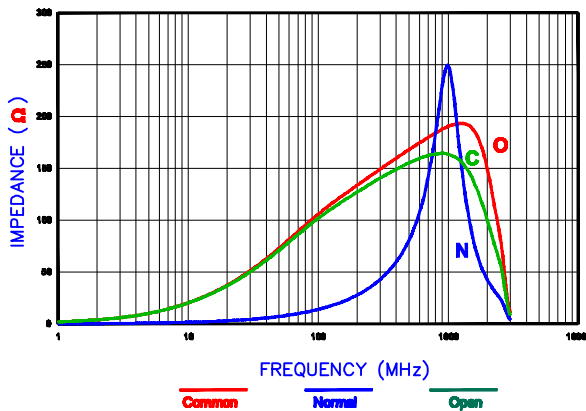

EQUIVALENT CIRCUIT

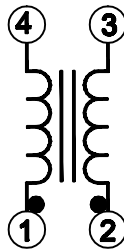

LAND PATTERNS FOR REFLOW SOLDERING

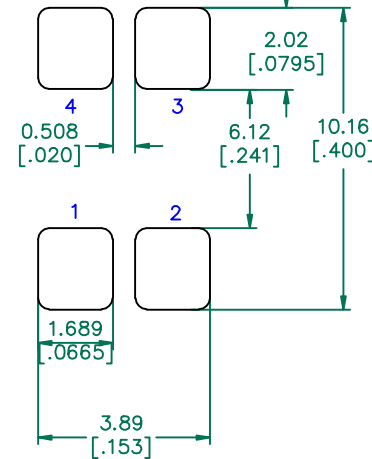

RECOMMENDED SOLDERING CONDITIONS

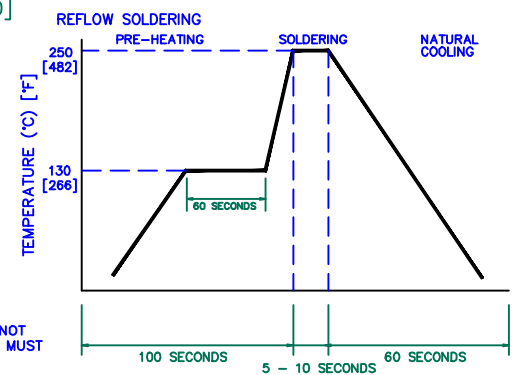

DURING AND AFTER SOLDERING OPERATION SOLDER MUST NOT BE ALLOWED TO BRIDGE CONTACTS. CONTACT SEPARATION MUST BE MAINTAINED.

Z, R, XL vs. FREQUENCY

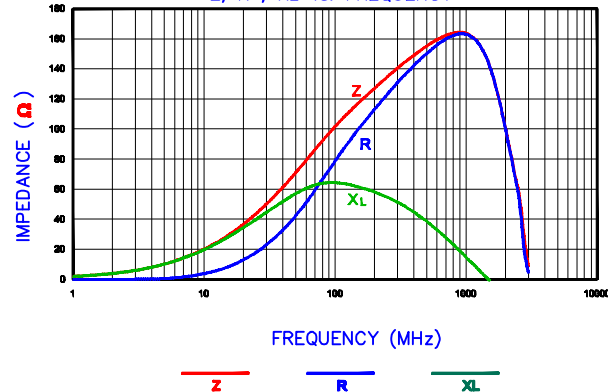

DIMENSIONS ARE IN mm [INCHES].				This print is the property of Laird Tech. and is loaned in confidence subject to return upon request and with the understanding that no copies shall be made without the written consent of Laird Tech. All rights to design or invention are reserved.			
E	UPDATE COMPANY LOGO ADD PIN NO. ADD EQUIVALENT CIRCUIT	11/19/08	JRK				
D	UPDATE COMPANY LOGO	11/26/07	JRK				
C	CHG E DIMS FROM .023 ADD RADIUS TO PART CHANGE DIMENSIONS ON LAND PATTERN	11/01/06	JRK				
B	CORRECT OCN CURVE DATA	04/20/06	JRK				
A	ORIGINAL DRAFT	07/27/05	JRK				
PROJECT/PART NUMBER: CM3312R111R-10				REV: E	PART TYPE: CO-FIRE	DRAWN BY: JRK	
DATE: 07/27/05				SCALE: NTS		SHEET: 2 of 2	
REV: DESCRIPTION				DATE: INT	CAD #: CM3312R111R-10-E		TOOL #: CM3312